

Mobile ML55 Frame

Before you order:

The manufacturer has made several changes that require you to look very closely at these drawings and your pallet jack. Check our notes to identify the parts you need.

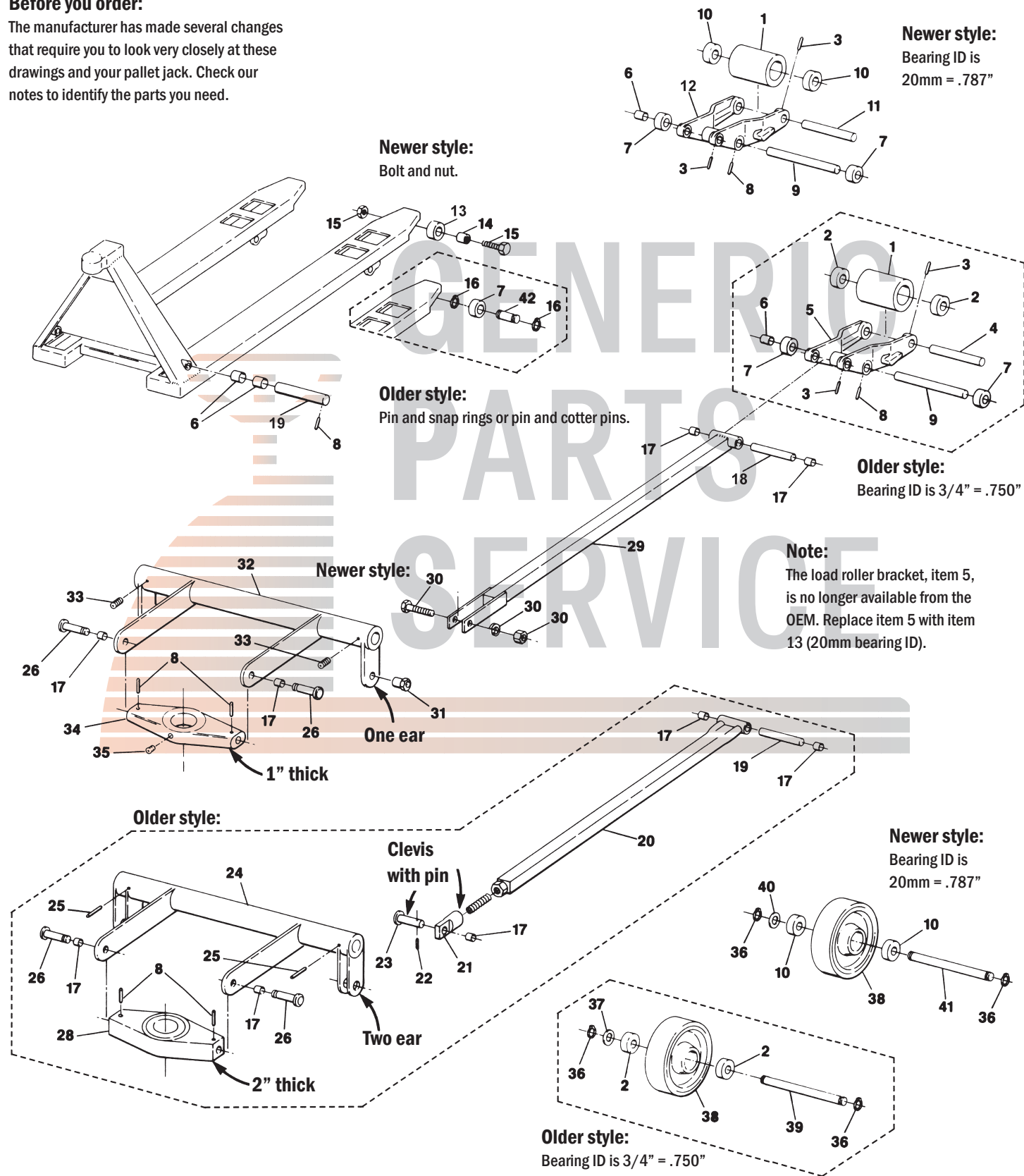

Mobile ML55 Frame

Item	Part No.	Description
1	203/210-A-D	Load Roller Assembly, Red Ultra-Poly On Aluminum Hub W/ Bearings, 3/4" ID Bearing
	203/210-A	Load Roller Assembly, Black Ultra-Poly On Steel Hub W/ Bearings, 3/4" ID Bearing
	204/210-A	Load Roller Assembly, Nylon W/ Bearings, 3/4" ID Bearing
	200/210-A	Load Roller Assembly, Steel W/ Bearings, 3/4" ID Bearing
	203/210-1-A-D	Load Roller Assembly, Red Ultra-Poly On Aluminum Hub W/ Bearings, 20mm ID Bearings
	203/210-1-A	Load Roller Assembly, Black Ultra-Poly On Steel Hub W/ Bearings, 20mm ID Bearings
	204/210-1-A	Load Roller Assembly, Nylon W/ Bearings, 20mm ID Bearing
	200/210-1-A	Load Roller Assembly, Steel W/ Bearings, 20mm ID Bearing
	GWK-ML55-LW	Load Wheel Kit, (2) Ultra-Poly Load Roller Assemblies W/ Bearings, Axles and Fasteners 20mm ID Bearing
2	210	Bearing, 3/4" ID
3	404	Roll Pin
4	211	Load Roller Axle, 3/4" Bearing (Older Style)
5	400	Load Roller Bracket, Replace W/ Item 12
6	610	Bushing
7	402	Entry or Exit Roller
8	609	Roll Pin
9	214	Pivot Axle
10	210-1	Bearing, 20mm ID
11	211-1	Load Roller Axle, 20mm Bearing (Older Style)
12	400-1	Load Roller Bracket (Newer Style)
13	300	Entry Roller
14	311	Bushing
15	310	Bolt and Nut
16	2050	Snap Ring
	303	Cotter Pin (Not Shown)
17	606	Bushing
18	515	Push Rod Axle
19	611	Lifting Link Shaft (Older Style)
	611-1	Lifting Link Shaft (Newer Style)
20	500	Push Rod, 36" Forks
	501	Push Rod, 42" Forks
	502	Push Rod, 48" Forks

Item	Part No.	Description
21	520	Clevis
22	404	Roll Pin
23	512	Pin
24	650	Lifting Link, 20-1/2" Wide Jack
	651	Lifting Link, 27" Wide Jack
25	612	Roll Pin
26	605	Shoulder Pin
28	2009	Traverse (2" Thick)
29	505	Push Rod, 48" Forks (Newer Style)
30	526	Bolt, Nut and Washer
31	525	Eccentric
32	655	Lifting Link, 20-1/2" Wide Jack
	656	Lifting Link, 27" Wide Jack
33	2053	Set Screw
34	657	Traverse (1" Thick)
35	658	Grease Fitting
36	2050	Snap Ring
37	103	Washer
38	101/210-A-HD	Steer Wheel Assembly, Red Ultra-Poly On Aluminum Hub W/ Bearings, 3/4" ID Bearing
	101/210-A-ST	Steer Wheel Assembly, Poly On Nylon Hub W/ Bearings, 3/4" ID Bearing
	100/210-A	Steer Wheel Assembly, Steel W/ Bearings, 3/4" ID Bearing
	101/210-1-A-HD	Steer Wheel Assembly, Red Ultra-Poly On Aluminum Hub W/ Bearings, 20mm ID Bearings
	101/210-1-A-ST	Steer Wheel Assembly, Poly On Nylon Hub W/ Bearings, 20mm ID Bearings
	100/210-1-A	Steer Wheel Assembly, Steel W/ Bearings, 20mm ID Bearing
	GWK-ML55-CK	Complete Wheel Kit, (2) Ultra-Poly Load Roller Assemblies (70D), (2) Poly Steer Wheel Assemblies, W/ Bearings, Axles & Fasteners
39	104	Steer Wheel Axle, 3/4" Diameter
40	103-1	Washer
41	104-1	Steer Wheel Axle, 20mm Diameter
42	302	Pin (Snap Ring Style)